

Agilent U9391C Comb Generator

Operating and Service Manual



Agilent Technologies

Notices

© Agilent Technologies, Inc. 2008

No part of this manual may be reproduced in any form or by any means (including electronic storage and retrieval or translation into a foreign language) without prior agreement and written consent from Agilent Technologies, Inc. as governed by United States and international copyright laws.

Manual Part Number

U9391-90001

Edition

First Edition, June 2008

Printed in Malaysia

Agilent Technologies, Inc.

Phase 3 Bayan Lepas Free Industrial Zone
Bayan Lepas, Penang 11900 Malaysia

Warranty

The material contained in this document is provided “as is,” and is subject to being changed, without notice, in future editions. Further, to the maximum extent permitted by applicable law, Agilent disclaims all warranties, either express or implied, with regard to this manual and any information contained herein, including but not limited to the implied warranties of merchantability and fitness for a particular purpose. Agilent shall not be liable for errors or for incidental or consequential damages in connection with the furnishing, use, or performance of this document or of any information contained herein. Should Agilent and the user have a separate written agreement with warranty terms covering the material in this document that conflict with these terms, the warranty terms in the separate agreement shall control.

Technology Licenses

The hardware and/or software described in this document are furnished under a license and may be used or copied only in accordance with the terms of such license.

Restricted Rights Legend

U.S. Government Restricted Rights. Software and technical data rights granted to the federal government include only those rights customarily provided to end user customers. Agilent provides this customary commercial license in Software and technical data pursuant to FAR 12.211 (Technical Data) and 12.212 (Computer Software) and, for the Department of Defense, DFARS 252.227-7015 (Technical Data - Commercial Items) and DFARS 227.7202-3 (Rights in Commercial Computer Software or Computer Software Documentation).

Safety Notices

CAUTION

A **CAUTION** notice denotes a hazard. It calls attention to an operating procedure, practice, or the like that, if not correctly performed or adhered to, could result in damage to the product or loss of important data. Do not proceed beyond a **CAUTION** notice until the indicated conditions are fully understood and met.

WARNING

A **WARNING** notice denotes a hazard. It calls attention to an operating procedure, practice, or the like that, if not correctly performed or adhered to, could result in personal injury or death. Do not proceed beyond a **WARNING** notice until the indicated conditions are fully understood and met.

Certification

Agilent Technologies certifies that this product met its published specifications at the time of shipment from the factory. Agilent Technologies further certifies that its calibration measurements are traceable to the United States National Institute of Standards and Technology (NIST, formerly NBS), to the extent allowed by the Institute's calibration facility, and to the calibration facilities of the other International Standards Organization members.

WEEE Compliance



This product complies with the WEEE Directive (2002/96/EC) marking requirements. The affixed label indicates that you must not discard this electrical/electronic product in domestic household waste.

Product Category: With reference to the equipment types in the WEEE Directive Annex I, this product is classed as a "Monitoring and Control Instrumentation" product.

Do not dispose in domestic household waste.

To return unwanted products, contact your local Agilent office, or see www.agilent.com for more information.

Contacting Agilent

For more information, please contact your nearest Agilent office.

Americas

Canada	(877) 894-4414
Latin America	305 269 7500
United States	(800) 829-4444

Asia Pacific

Australia	1 800 629 485
China	800 810 0189
Hong Kong	800 938 693
India	1 800 112 929
Japan	81 426 56 7832
Korea	080 769 0800
Malaysia	1 800 888 848
Singapore	1 800 375 8100
Taiwan	0800 047 866
Thailand	1 800 226 008

Europe

Austria	0820 87 44 11
Belgium	32 (0) 2 404 93 40
Denmark	45 70 13 15 15
Finland	358 (0) 10 855 2100
France	0825 010 700
Germany	01805 24 6333
Ireland	1890 924 204
Italy	39 02 92 60 8484
Netherlands	31 (0) 20 547 2111
Spain	34 (91) 631 3300
Sweden	0200-88 22 55
Switzerland(French)	41 (21) 8113811 (Opt 2)
Switzerland(German)	0800 80 53 53 (Opt 1)
United Kingdom	44 (0) 118 9276201
Other European Countries:	www.agilent.com/find/contactus

Or, go to www.agilent.com/find/assist for more information.

Contents

1	Introduction	7
	Product Overview	8
	Key Features of Agilent U9391C Comb Generator	9
	Compatible Agilent Network Analyzer	10
	Options	10
	Service and Recertification	10
2	Installation	11
	Initial Inspection	12
	Operating and Safety Precautions	13
	ESD Damage	13
	Comb Generator and Agilent PNA-X Configurations	15
3	Specification	17
	General Specifications	18
	Drive Power Supply Specifications	18
	Physical Specification	18
	Mechanical Characteristic	20
	Pin Depth	20
	Environmental Specifications	24
	Compliance Notices and Regulatory Information	25
	Compliance With Electromagnetic Compatibility (EMC)	25
	Declaration of Conformity	26
4	Operating Guides	29
	Operating Instruction	30
	Operator's Check	30

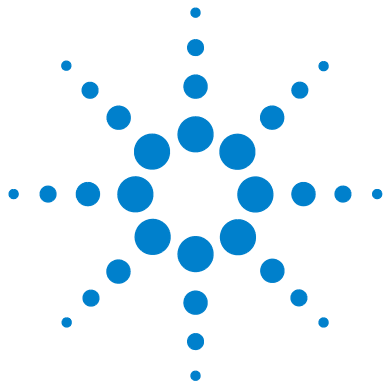

1 Introduction

Product Overview 8

“Key Features of Agilent U9391C Comb Generator” on page 9

“Compatible Agilent Network Analyzer” on page 10

“Options” on page 10

“Service and Recertification” on page 10

This chapter provides an overview specifications of Agilent U9391C Comb Generator



Product Overview

The U9391C comb generator was designed as a phase reference standard for the Agilent PNA- X nonlinear vector network analyzer (NVNA). It was developed to provide precision phase calibration, traceable to the National Institute of Standards and Technology (NIST).

NVNA component characterization software converts a 4- port PNA- X with option 510 into an innovative, high- performance, non- linear network analyzer which uses U9391C comb generators as precision phase calibration standards. Comb generators generate frequency harmonics at integer multiples of an RF input signal.

Generally, comb generators available in the open market today are made with SRD diodes, U9391C comb generators are based on Agilent InP MMIC technology to ensure superior phase stability of the combs.



Figure 1-1 U9391C Comb Generator

The U9391C comb generator offers the advantage of wide bandwidth 10MHz to 26.5GHz output and small minimum tone spacing (10MHz). When driven by low phase noise sources, this comb generator will operate at frequencies lower than 10MHz, but performance is not guaranteed. The input power and fundamental frequency have lower sensitivity than other comb generators. This means a comb generator calibrated at a single power level and frequency can be used across a wide range of input power. It comes with the option of a female or male output connector.

U9391C modules are solid state devices which provide excellent phase and amplitude flatness in the combs making them ideal for use in phase calibration applications. A built-in frequency divider, selectable via the PNA-X, reduces the noise of the combs. You can set drive frequency at 1, 2, 4, 8 or 16 times the pulse repetition frequency (PRF). Combining a frequency divider with a wide input signal frequency range allows for a broad range of possible harmonics spacing, making this suitable for characterizing non-linear devices. This module has a trigger output which enables synchronization with the pulse's repetition frequency. Calibration data stored inside the U9391C can be accessed directly by the PNA-X via the USB interface to be used in phase calibration.

Key Features of Agilent U9391C Comb Generator

- Excellent amplitude and phase flatness enable it to be used as a precision calibration phase reference standard for the NVNA
- NIST traceable phase calibration guarantees a reliable reference to international standards
- Embedded calibration data can be easily accessed via the plug-and-play USB interface
- The USB interface further facilitates frequency divider control and calibration data retrieval via the PNA-X.
- Rugged 3.5mm bulk-head connectors guarantee high repeatability throughout multiple connects and disconnects.

Compatible Agilent Network Analyzer

The U9391C comb generator are designed to operate with Agilent PNA- X nonlinear vector network analyzer (NVNA). The U9391C comb generator modules are controlled by the N5242A PNA- X network analyzer via a USB connection with options required: 400, 419, 080, 510. N5242A PNA- X network analyzers can be upgraded to perform non-linear component characterization.

Options

There are two connector options available for Agilent U9391C Comb Generator.

- Option FFF - 3.5mm Female (Output connectors)
- Option FFM - 3.5mm Male (Output connectors)

NOTE

The Trigger and Input ports are of 3.5mm Female connectors, for both the options above

Service and Recertification

If your Comb generator modules require service or recertification, contact the nearest Agilent office for information on where to send it. Refer to “Contacting Agilent” in the front matter of this manual. The performance of the comb generator modules can only be verified by specially manufactured equipment and calibration standards from Agilent.

Recertification of Comb Generator Modules

The suggested interval for recertification is 12 months. After reviewing the result of the initial recertification, you may establish a shorter interval that reflects greater use and wear of the module.

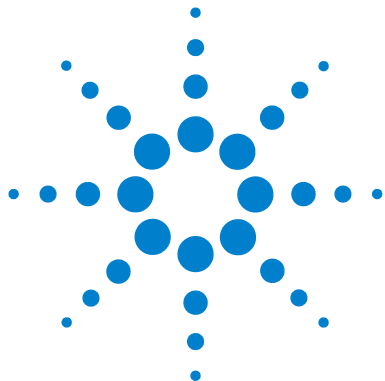

2 Installation

Initial Inspection 12

Operating and Safety Precautions 13

Comb Generator and Agilent PNA-X Configurations 15

This chapter provides you important information on how to check your instrument and preparation for operation.



Initial Inspection

- 1 Unpack and inspect the shipping container and its contents thoroughly to ensure that nothing was damaged during shipment. If the shipping container or cushioning material is damaged, the contents should be checked both mechanically and electrically.
 - Check for mechanical damage such as scratches or dents
 - Procedures for checking electrical performance are given under “Operator’s Check” on page 30.
- 2 If the contents are damaged or defective, contact your nearest Agilent Technologies Service and Support Office. Refer to the Service and Support information in the front matter of this manual. Agilent Technologies will arrange for repair or replacement of the damaged or defective equipment. Keep the shipping materials for the carrier’s inspection.
- 3 If you are returning the instrument under warranty or for service, repackaging the instrument requires original shipping containers and material or their equivalents. Agilent Technologies can provide packaging materials identical to the original materials. Refer to Service and Support information in the front matter of this manual for the Agilent Technologies nearest to you. Attach a tag indicating the type of service required, return address, model number and serial number. Mark the container **FRAGILE** to insure careful handling. In any correspondence, refer to the instrument by model number and serial number.

Kit Contents

The following table lists the item in U9391C kit.

Table 2-1 U9391C Kit Contents

QUANTITY	DESCRIPTION	PART NUMBER
1	DC cable assembly - Banana plug	87405-20006
1	USB cable	8121-0506

Operating and Safety Precautions

Observe the following guidelines before connecting or operating the Comb Generator modules.

ESD Damage

Protection against electrostatic discharge (ESD) is important while handling and operating the Agilent U9391C Comb Generator module.

Static electricity can build up on your body and can easily damage sensitive components when discharged.

Static discharges too small to be felt can cause permanent damage to the unit.

To prevent damage from ESD:

- **Use** a grounded antistatic mat in front of your test equipment and wear a grounded wrist strap attached to it when handling or operating the Comb Generator module.
- **Wear** a heel strap when working in an area with a conductive floor.
- **Ground** yourself before you clean, inspect or make a connection to an Comb Generator module. You can, for example, grasp the grounded outer shell of the analyzer test port or cable connector briefly.
- **Avoid** touching the center conductor of the test ports.

Connector Care

Because connectors can become defective due to wear during normal use, all connectors should be inspected and maintained to maximize their service life.

- **Inspect** the mating surface each time a connection is made. Metal particles from connector threads often find their way onto the mating surface when a connection is made or disconnected.
- **Clean** dirt and contamination from the connector mating surface and threads. This simple step can extend the service life of the connector and improve the quality of your calibration and measurements.
- **Gage** connectors periodically. This not only provides assurance of proper mechanical tolerances, and thus connector performance, but can also indicate situations where the potential for damage to another connector may exist.

CAUTION

The Agilent Comb Generator modules can be damaged if apply excessive torque to the connectors.

The recommended torque value is 8lb-in torque.

Comb Generator and Agilent PNA-X Configurations

Two units of U9391C are required to carry out non-linear measurements. One unit is used as the phase reference module and the second unit as the phase calibration module.

The U9391C units need to be powered by separate power supplies.

The NVNA software automatically controls the U9391C units via USB after the two units have been selected as the phase reference and phase calibration module respectively.

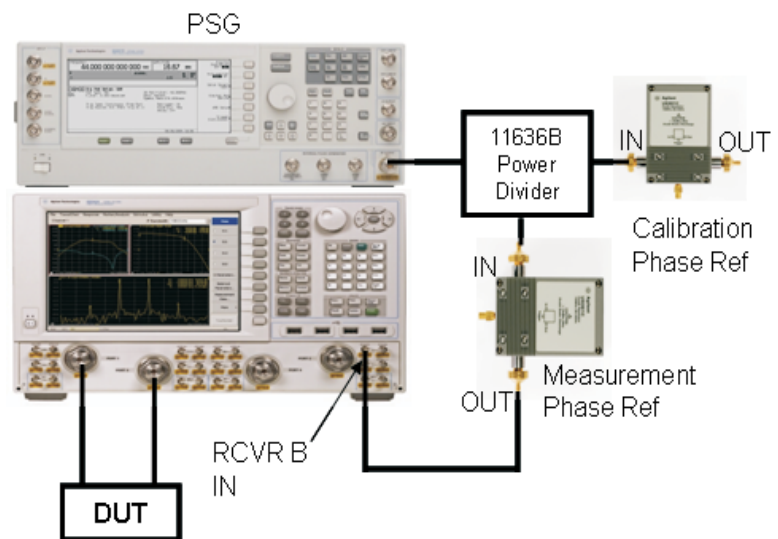

Figure 2-1 U9391C Comb Generator and PNA-X Configuration

The phase calibration procedure is carried out by following the on-screen instructions on the PNA-X.

After completing the calibration, the U9391C unit used for phase calibration can be disconnected. The other unit that is used as the phase reference will remain connected while the measurement is carried out.

For more detailed information, please refer to the Help file that is embedded in the NVNA application.

CAUTION

When connecting the U9391C comb generators directly to the instrument test ports, the modules will require mechanical support so as not to overstress the test port connectors.



3 Specification

General Specifications	18
“Drive Power Supply Specifications”	on page 18
“Physical Specification”	on page 18
“Specifications”	on page 19
Mechanical Characteristic	20
“Typical Pin Depth Values”	on page 22
“Mechanical Dimension of the Modules”	on page 23
Environmental Specifications	24

This chapter provides an overview specifications of Agilent U9391C Comb Generator



General Specifications

Drive Power Supply Specifications

Table 3-1 U9391C Comb Generator Drive Power Supply Specification

Voltage	+15± 20% Vdc
Current	300mA (nominal)

NOTE

Recommended DC power supply: E3620A

Compatible DC power supply: All E36XXA series power supply (except E3612A and E3614A).

Current drawn will change when drive voltage changes

Physical Specification

Net weight	0.370kg
Shipping weight	3.155kg
Shipping dimension	
Length	52.5cm
Width	34cm
Height	19.5cm

Specifications

Specifications refer to the performance standards or limits against which the U9391C comb generator are tested.

Typical characteristics are included for additional information only and they are not specifications. These are denoted as “typical”, “nominal” or “approximate” and are printed in italic.

Table 3-2 U9391C Comb Generator Specifications

Output frequency range [*]	10MHz to 26.5GHz
Input frequency range	10MHz to 6GHz
Input power range	-15 to +15 dBm
Min output power per picket	-80dBm at 10MHz Input PRF
Amplitude flatness vs. Output frequency	< 12dB at 10MHz Input PRF
Amplitude flatness vs. input power	<i>0.1dB (typical)</i>
Phase flatness [†]	+/- 8.5 degrees (10MHz to 3GHz) +/- 6.5 degrees (3GHz to 20GHz) +/- 8.5 degrees (20GHz to 26.5GHz)
Pulse width (ps)	< 23
Divide ratio	1, 2, 4, 8, 16
Input Return Loss, S11	> 10dB (10MHz to 6GHz)
Output Return Loss, S22	> 10dB (10MHz to 26.5GHz)

* When driven by low phase noise sources, this comb generator will operate at frequencies lower than 10MHz, but performance is not guaranteed.

† Not at spurious frequency. Spurious frequency at $n \times 250\text{MHz}$ and also at input drive frequency.

Mechanical Characteristic

Mechanical characteristics, such as center conductor protrusion and pin depth are not warranted performance specifications.

They are however important supplemental characteristics related to the electrical performance of the devices.

Agilent Technologies verifies the mechanical characteristics of the devices with special gaging processes and electrical testing.

These processes ensure that the device connectors do not exhibit any excess center conductor protrusion or improper pin depth when the module leaves the factory.

Pin Depth

Pin depth is the distance the center conductor mating plane differs from being flush with the outer connector mating plane.

The pin depth of a connector can be in one of two states: protrusion or recession.

Protrusion occurs when the center conductor extends beyond the outer conductor mating plane. It reads as a positive value on the connector gage.

Recession occurs when the center conductor is set back from the outer conductor mating plane. It reads as a negative value on the gage.

The pin depth for a 3.5mm connector is shown in [Figure 3-1](#).

The typical pin depths for U9391C connectors are listed in “[Typical Pin Depth Values](#)” on page 22.

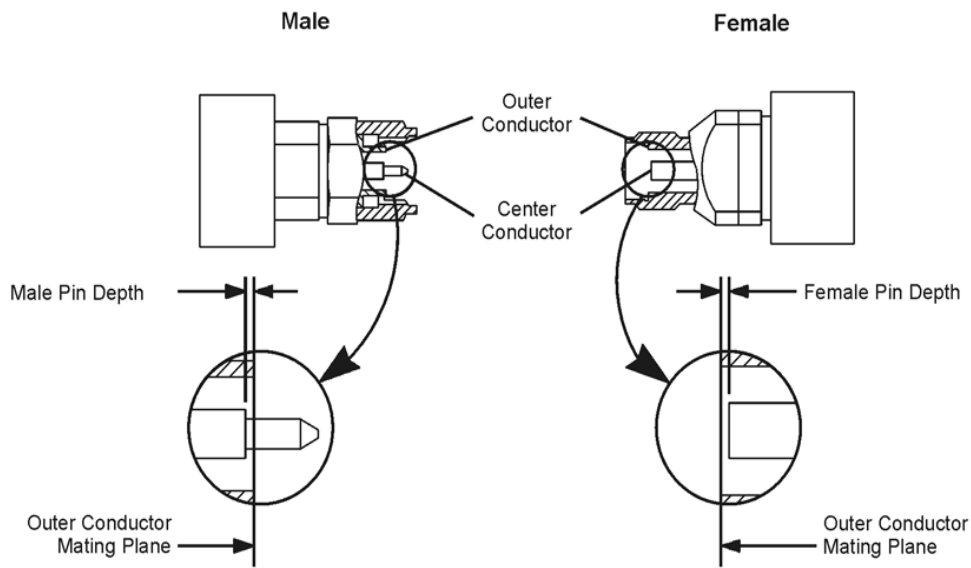

Figure 3-1 Pin depth for a 3.5mm connectors

Typical Pin Depth Values

The pin depth value of each device is not specified, but is an important mechanical parameter.

The electrical performance of the device depends, to some extent, on its pin depth.

The electrical specifications for each module takes into account the effect of pin depth on the device's performance.

The following tables list the typical pin depths for the devices.

Table 3-3 U9391C Comb Generator Pin Depth Characteristic

Port	Typical Pin Depth in Micrometers (10 ⁻⁴ inches)
In/ Out port	0 to -50.8 (0 to -20.0)
Trigger port	0 to -127.0 (0 to -50.0)

If the pin depth of a device does not measure within the observed pin depth limits, it may be an indication that the device fails to meet electrical specification.

Mechanical Dimension of the Modules

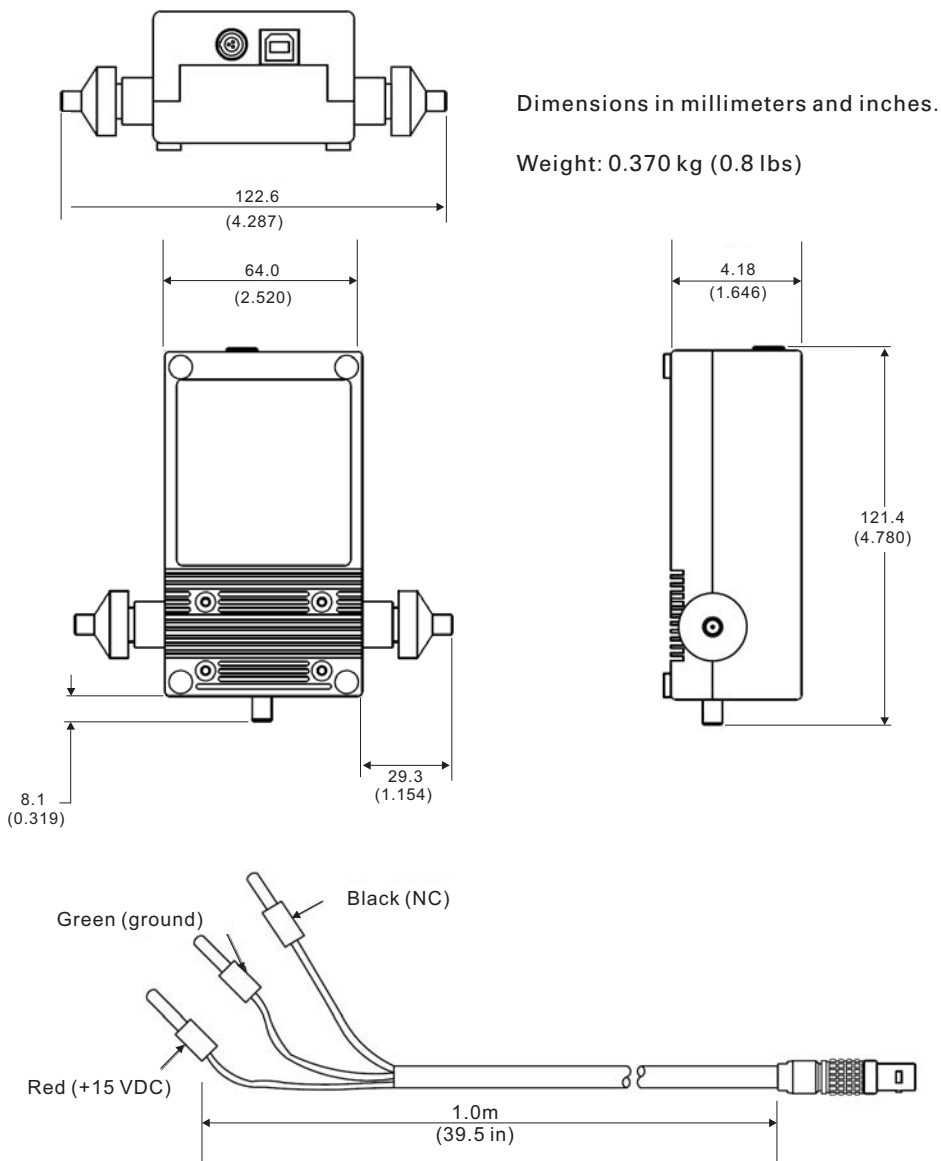

Figure 3-2 Mechanical Dimension of U9391C Comb Generator

Environmental Specifications

Agilent U9391C comb generators are designed to fully comply with Agilent Technologies’s product operating environment specifications. The following are the summarized environmental specifications for these product.

Table 3-4 U9391C Comb Generator Environmental Specifications

Temperature	
• Operating	0°C to +55°C
• Storage	-40°C to +70°C
• Error corrected range	23°C to +/- 3°C
• Cycling	-65°C to +85°C, 10 cycles at 20°C per minute. 20 minutes dwell time per MIL-STD-883F, Method 1010.8, Condition C (modified)
Relative Humidity	
• Operation	50% to 95% RH at 40°C, 24 hours cycling, repeated 5 times
• Storage	90% RH at 65°C, one 24 hour cycle
Shock	
• End-use handling shock	Half-sine wave form, 2-3ms duration, 60 in/s (1.6ms) delta-V
• Transportation shock	Trapezoidal wave form, 18-22ms duration, 337 in/s (8.56ms) delta-V
Vibration	
• Operating	Random: 5-500Hz, 0.21grms, 10min/axis
• Survival	Random: 5-500Hz, 2.09grms, 10min/axis Swept Sine: 5-500Hz, 0.5grms, 10min/axis, 4 resonance search, 10min dwell
Altitude	
• Operating	< 4,572 meters (15,000 feet)
• Storage	< 15,000 meters (50,000 feet)
ESD immunity:	
• Direct discharge *	8.0 kV per IEC 61000-4-2
• Air discharge	15 kV per IEC 61000-4-2

* To outer conductor

Compliance Notices and Regulatory Information

Compliance With Electromagnetic Compatibility (EMC)

This product conforms with the protection requirements of EMC Directive 2004/108/EC for Electromagnetic Compatibility.

The product comply to the EMC Directive by assessment according to IEC/EN61326- 1 EMC standard.

In order to preserve the EMC performance of the product, any cable which becomes worn or damaged must be replaced with the same type and specifications.

Refer to the [“Declaration of Conformity”](#) on page 26.

Regulatory Markings



The CE mark shows that the product complies with all the relevant European Legal Directives.

ISM 1-A

ICES/NMB-001 indicates that this ISM device complies with Canadian ICES-001.

Cet appareill ISM est conforme a la norme NMB-001 du Canada.

ICES/NMB -001

This is the symbol of an Industrial Scientific and Medical Group 1 Class A product.



The C-Tick mark is a registered trademark of the Spectrum Management Agency of Australia. This signifies compliance with the Australian EMC Framework Regulations under the terms of the Radio communications Act of 1992.

Declaration of Conformity

 Agilent Technologies	DECLARATION OF CONFORMITY <small>According to EN ISO/IEC 17050-1:2004</small>	
---	---	---

Manufacturer's Name: Agilent Technologies Microwave Products (M) Sdn. Bhd
Manufacturer's Address: Bayan Lepas Free Industrial Zone,
 11900, Bayan Lepas, Penang, Malaysia

Declares under sole responsibility that the product as originally delivered

Product Name: Comb Generator
Models Number: U9391C
Product Options: This declaration covers all options of the above product(s)

complies with the essential requirements of the following applicable European Directives, and carries the CE marking accordingly:

EMC Directive (2004/108/EC)

and conforms with the following product standards:

EMC	Standard	Limit
	IEC 61326:2002 / EN 61326:1997+A1:1998+A2:2001+A3:2003	
	CISPR 11:1990 / EN55011:1990	Class A Group 1
	IEC 61000-4-2:1995 / EN 61000-4-2:1995	4 kV CD, 8 kV AD
	IEC 61000-4-3:1995 / EN 61000-4-3:1995	3 V/m, 80-1000 MHz
	IEC 61000-4-4:1995 / EN 61000-4-4:1995	0.5 kV signal lines, 1 kV power lines
	IEC 61000-4-5:1995 / EN 61000-4-5:1995	0.5 kV line-line, 1 kV line-ground
	IEC 61000-4-6:1996 / EN 61000-4-6:1996	3 V, 0.15-80 MHz
	IEC 61000-4-11:1994 / EN 61000-4-11:1994	1 cycle / 100%

Canada: ICES-001:2004
 Australia/New Zealand: AS/NZS CISPR11:2004

The product was tested in a typical configuration with Agilent Technologies test systems.

Supplementary Information:

U9391C has input voltage below the requirements specified in the Low Voltage Directive. Only EMC Directive is applicable for this product.

This DoC applies to above-listed products placed on the EU market after:

<p>_____ 23-May-2008 Date</p>	 _____ Tay Eng Su Quality Manager
---	--

For further information, please contact your local Agilent Technologies sales office, agent or distributor, or Agilent Technologies Deutschland GmbH, Herrenberger Straße 130, 71034 Böblingen, Germany.

Product Regulations**EMC****Performance Criteria**

IEC 61326-1:2002 / EN 61326-1:1997+A1:1998+A2:2001+A3:2003

CISPR 11:1990 / EN 55011:1990 – Group 1 Class A

IEC 61000-4-2:1995 / EN 61000-4-2:1995 (ESD 4kV CD, 8kV AD)

IEC 61000-4-3:1995 / EN 61000-4-3:1996 (3V/m, 80% AM)

IEC 61000-4-4:1995 / EN 61000-4-4:1995 (EFT 0.5kV line-line, 1kV line-earth)

IEC 61000-4-5:1995 / EN 61000-4-5:1995 (Surge 0.5kV line-line, 1kV line-earth)

IEC 61000-4-6:1996 / EN 61000-4-6:1996 (3V, 0.15–80 MHz, 80% AM, power line)

IEC 61000-4-11:1994 / EN 61000-4-11:1994 (Dips 1 cycle, 100%)

Canada: ICES-001:2004

Australia/New Zealand: AS/NZS CISPR11:2004

A
A
A
A
A
A**Additional Information:**

The product herewith complies with the essential requirements of the EMC Directive 2004/108/EC and carries the CE Marking accordingly (European Union).

¹Performance Criteria:

A Pass - Normal operation, no effect.

B Pass - Temporary degradation, self recoverable.

C Pass - Temporary degradation, operator intervention required.

D Fail - Not recoverable, component damage.

N/A – Not applicable

Notes:**Regulatory Information for Canada**

ICES/NMB-001:2004

This ISM device complies with Canadian ICES-001.

Cet appareil ISM est conforme à la norme NMB-001 du Canada.

Regulatory Information for Australia/New Zealand

This ISM device complies with Australian/New Zealand AS/NZS CISPR11:2004



3 Specification

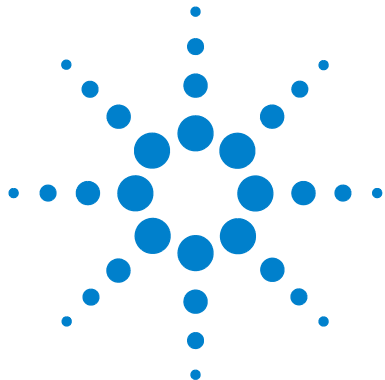

4 Operating Guides

Operating Instruction 30

“Operator’s Check” on page 30

Service Instructions 37

This chapter provides you a simple quick-check instruction to verify Agilent U9391C Comb Generators’ functionality prior to usage.



Operating Instruction

Operator's Check

The operator's check is supplied to allow the operator to make quick check of the comb generator prior to use or if a failure is suspected.

CAUTION

ESD exceeding the level specified in **Table 3-4** or RF power applied is greater than the maximum specified as in **Table 3-2** may cause permanent damage to the device.

Operator's Check for S-Parameter Test

Recommended Test Equipment

[Table 4-1](#) and [Table 4-2](#) below lists the test equipment required for performance test verification. Equipment other than the recommended models can be used, provided minimum specifications are satisfied.

Table 4-1 Recommended Test Equipment

Instrument Type	Setting
N5242A Network Analyzer (option 400, 419, 080, 510)	PNA-X application <ul style="list-style-type: none"> • Start Frequency: 10MHz • Stop Frequency: 26.5GHz • Power Level: -20dBm • No of points: 201
E3631A DC Power Supply	<ul style="list-style-type: none"> • Voltage: +15Vdc • Current: 2 x 0.3A*

* To power up 2 units of U9391C

Quick-Check Procedure

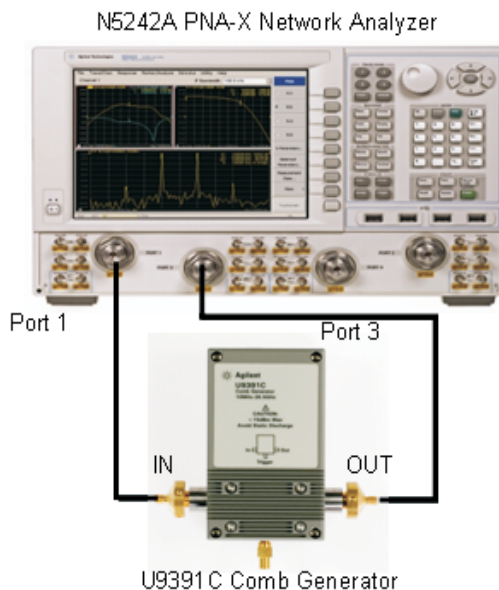

Figure 4-1 Quick-check Configuration for S-parameter Test

The equipment setup is as illustrated in [Figure 4-1](#).

- 1** Click on PNA-X application. Calibrate the network analyzer with full 2- port calibration using the appropriate electronic or mechanical calibration kit.
- 2** Connect Input of comb generator to Port 1 of network analyzer and Output of comb generator to Port 2 of network analyzer.
- 3** Turn ON the biasing of the comb generator by connecting to power supply, +15V, 0.3A.
- 4** Get the measurement for Input Return Loss (S11) and Output Return Loss (S22).
- 5** Compare measurement results with specification in Table 3-2 on page 19.

Operator's Check for Nonlinear Vector Network Analyzer (NVNA) Test

Table 4-2 Recommended Test Equipment

Instrument Type	Setting
N5242A Network Analyzer (option 400, 419, 080, 510)	NVNA application <ul style="list-style-type: none"> • Start & Stop Frequency: 10MHz • Frequency points: 1 • Maximum Harmonics: 2650
E3631A DC Power Supply	<ul style="list-style-type: none"> • Voltage: +15Vdc • Current: 2 x 0.3A*
E8267D PSG Signal source or any source that can provide 10MHz to 6GHz RF output	• N/A
Power meter	• N/A
E4413A Power sensor or U2002A USB Power sensor	• N/A
11636B Power Divider	• N/A

* To power up 2 units of U9391C

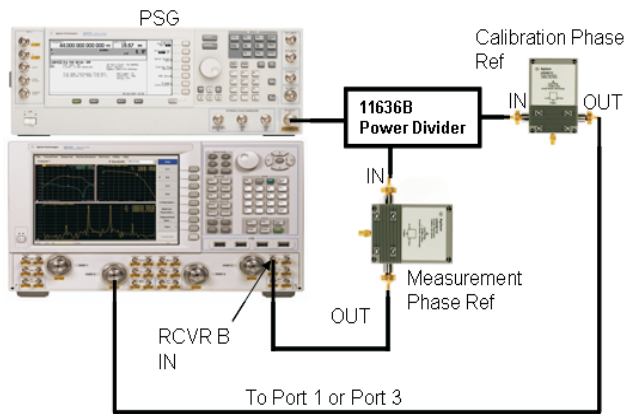

Figure 4-2 Quick-check Configuration for NVNA Test

Quick-Check Procedure

The equipment setup is as illustrated in [Figure 4-2](#).

- 1 Connect GPIB linking PNA- X, PSG and Power Meter.
- 2 Power up both the phase reference units and also connect the USB cable to the PNA- X.
- 3 Shutdown the network analyzer application and turn on NVNA application. Leaving the network analyzer application running in the background will cause the NVNA applications to not function properly.
- 4 Click **Response** and select **Couple Segment** from Agilent Nonlinear Vector Network Analyzer main menu as shown in [Figure 4-3](#).
- 5 Again, click **Response** and select **Receiver Attenuation**. Set 10dB at Receive B portion and then click **OK**.
- 6 Set the parameters as following. Then click **Apply** button.
 - a Start and Stop frequency : 10MHz
 - b Frequency points : 1
 - c Maximum Harmonics : 2650
 - d IFBW : 10Hz

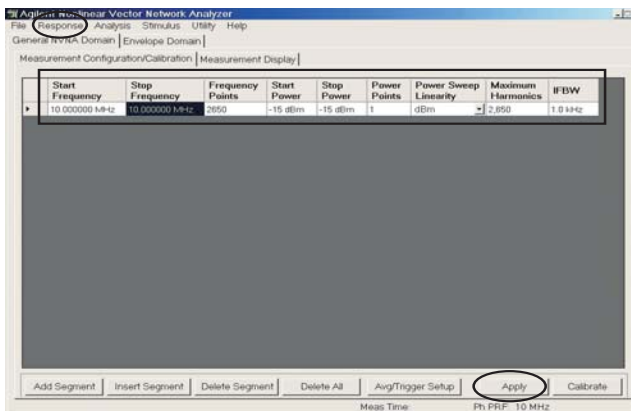

Figure 4-3 NVNA main menu

7 Click **Calibrate** button to start the NVNA Cal Wizard.

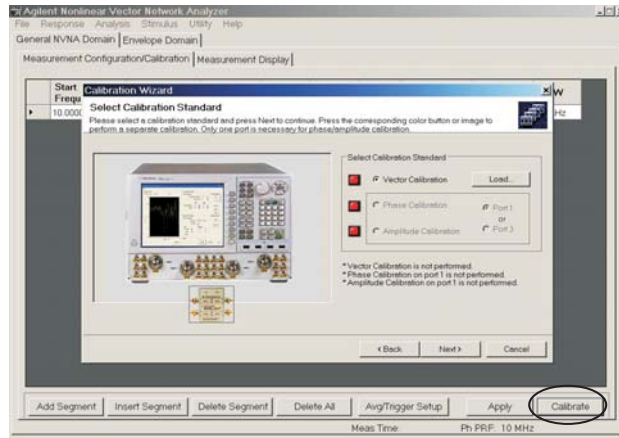

Figure 4-4 NVNA Calibration Wizard

- 8 Follow the on screen instruction on the PNA- X to perform calibration.
- 9 **Vector Calibration** must be performed first. Click **Load** to recall Cal Set data from a previously performed calibration. However, the stimulus settings for the Cal set must exactly match the current stimulus settings.
- 10 Select Port 1 or Port 3 and follow the instructions to perform the Amplitude Calibration using power sensor, before doing the Phase Calibration.

- To perform **Phase Calibration**, select the phase reference unit that is identified to use for calibration. Then click **Next** button.

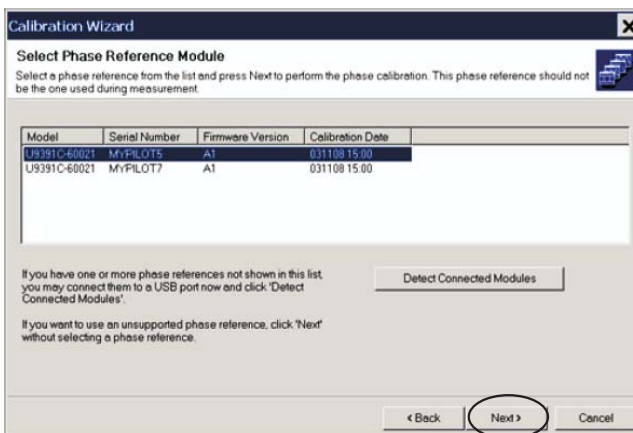

Figure 4-5 NVNA Calibration Wizard

- Connect the **Output** of phase reference unit (unit that has been selected as phase calibration) to **Port 3** of network analyzer once calibration is completed.

13 Click on the **Measurement Display** tab and select as following to perform comb amplitude and comb phase measurement.

- a Format** : select **Log Mag** (to measure comb amplitude) or **Phase** (to measure comb phase)
- b Domain** : select **Frequency**
- c Measure** : select **Single** or **Continuous**

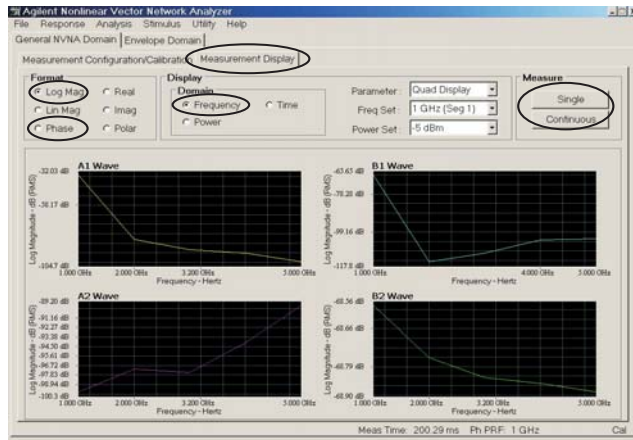

Figure 4-6 NVNA main menu

14 Compare measurement results with specification in Table 3-2 on page 19.

15 Phase measurement will fluctuate between +180 to -180 degrees due to phase wrapping.

Service Instructions

Repair

In case your comb generator module requires repair services, please contact your nearest Agilent Sales and Service Center.

Adjustment

The comb generator do not have internal adjustments and should not be opened.

Maintenance

The connectors, particularly the connector faces, must be kept clean. For instruction on connecting and care of your connectors, refer to the Microwave Connector Care Quick Reference Card (08510-90360).